

Processing Solutions for Plastics & Rubber

Processing plastics and rubber often requires exact temperatures and final moisture levels to ensure quality and reduce the rate of defects. High quality drying, cooling, quenching, dewatering, feeding, blending, screening, and conveying equipment from Carrier Vibrating Equipment is custom engineered to meet the specific needs of each production line.

Carrier has proven experience drying, cooling, and processing various plastics and rubber. From temperature-sensitive products to sticky or demanding rubber crumb, Carrier's line of processing equipment delivers an innovative solution for each specific application.



Trusted in these Industries over 70 Years

Equipment for Processing Plastics & Rubber:

- Vibrating Fluid Bed Dryers & Coolers
- Static Fluid Bed Dryers & Coolers
- Vibrating Spiral Elevators
- Vibrating Feeders
- Vibrating Conveyors

The Carrier logo, featuring the word "Carrier" in a bold, white, sans-serif font with a registered trademark symbol (®) to the right, all contained within a red rectangular background.

Fluid Bed Dryers & Coolers

Vibrating fluid bed dryers are ideal for processing temperature-sensitive plastics and rubber. Static fluid bed dryers and coolers are ideal for handling PVC plastics. The size of our fluid beds can be strategically engineered to control the moisture level and temperature to the required levels.

Features & Benefits

- High efficiency heat transfer for low temperature drying
- Zoning allows multiple functions to be performed in a single piece of equipment to optimize process efficiency
- Plug flow design delivers consistent first-in, first-out material output if required

Options

- Patented Delta-Phase® drive
- Variety of fluidizing deck designs
- Dry-only or dry & cool units
- Re-circulated gas and closed-loop systems
- Access manways & doors
- Custom controls

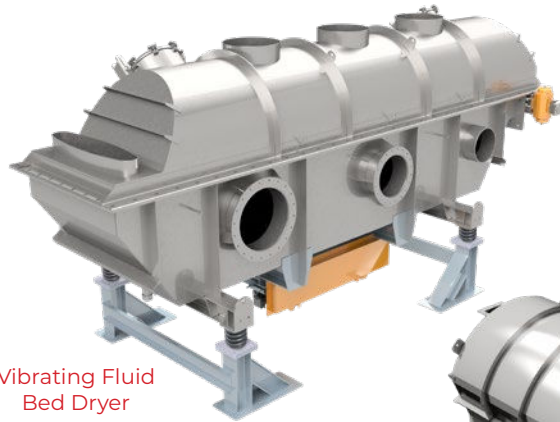

Vibrating Fluid Bed Dryer



Static Fluid Bed Dryer & Cooler



Patented Delta-Phase® Drive

Make on-line changes to the angle of vibration for precise control of retention time.

Vibrating Spiral Elevators

Vibrating spiral elevators are ideal solutions for cooling plastic and rubber in a small footprint. The constant motion of the product minimizes clumping or uneven cooling that would most likely be found in other technologies.

Features & Benefits

- Versatile design capable of heating or cooling while elevating products
- Adjustable stroke, speed, and retention time control
- Direct drive motor design eliminates over-stroke
- Available long stroke design minimizes buildup



Jacketed Flights

Jacketed flights can be used for indirect heat transfer with steam, oil, or water and are made of pre-formed, heavy-duty dimple plate.



Options

- Jacketed flights for indirect heat transfer
- Non-leaking water connections
- Enclosures
- Non-stick coatings

Vibrating Feeders

Vibrating feeders provide efficient and economical conveying of variety of bulk materials. Carrier feeders are available in tuned, two-mass, natural frequency, and direct-drive designs. They are customized in size and construction materials for processing plastics or rubber applications.

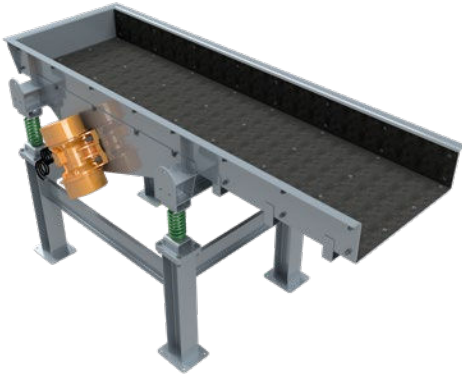

Features & Benefits

- Variable feed rates with optional VFD
- Drive units provide consistent conveying of materials in severe operating environments
- Large capacity vibrating feeders to handle heavy headloads are available
- Natural frequency drive units maintain stroke under extreme headloads for reliable operation
- Pedestal mounted on oscillating hydraulic base units are available to feed wide belt conveyors

Options

- Scalping or screening decks
- Removable dust-tight covers
- Overhead drive arrangement
- Isolation options
- Two-directional conveying
- Variety of discharge ports
- Non-stick coatings

Scalping / Screening Decks

Scalping, screening decks and custom units that accommodate multiple decks on a single unit are available.



Vibrating Conveyors

Long stroke vibrating conveyors eliminate crumb rubber bed matting and can be built with non-stick coatings to keep rubber and plastic products flowing, making cleaning between batches simple. Custom conveyors can quench, dewater, screen, spray wash, cool, and distribute materials.

Features & Benefits

- Multi-functional to convey, feed, heat, cool, scalp, screen, quench, dewater, accumulate, separate & distribute
- Few moving parts, easily-cleaned surfaces, and low maintenance compared to other conveyors
- Leak-proof, monolithic troughs eliminate spilling, waste, and contamination
- Simple to replace liners and trough surfaces

Options

- Two-way conveying
- Coil springs or leaf springs
- Perforated plates or screens
- Heating & cooling jackets
- Dust-tight designs
- Counterbalancing and/or isolating to minimize dynamic reactions
- Isolation options
- Magnets to eliminate metals
- Non-stick Coatings

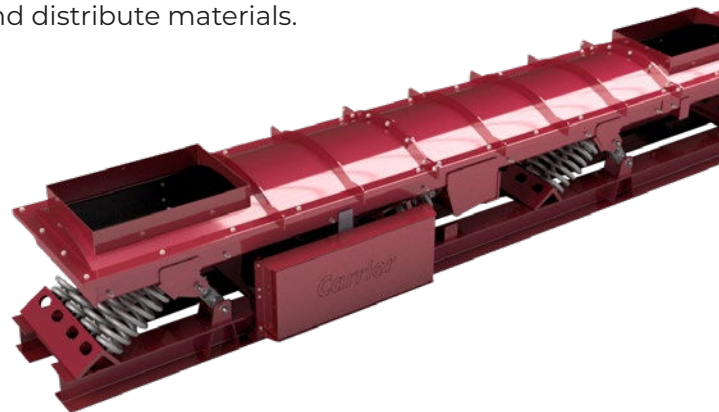

Two-Way Conveying

Convey in two directions if the process has more than one path.

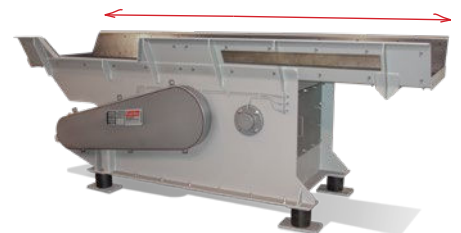



Engineering & Manufacturing

- Technology profile of over 150 patents
- Equipment designs are verified using Finite Element Analysis (FEA) to ensure trouble-free service and long life
- 3D equipment modeling
- State-of-the-art manufacturing facilities on 3 continents with robotic cutting and welding
- Manufacturing expertise working with mild steel, various grades of stainless steel, duplex steels and other exotic alloys for specialty applications
- Welders certified to ASME & AWS standards
- ISO 9001:2015 certified

Lab Testing

Be confident that your processing is efficient with CPEG's 15,000 ft² state-of-the-art test lab. With our lab, you have access to the most extensive testing capabilities in the industry. Multiple pieces of equipment can be combined for multistep and multistage testing to simulate field operation, validate new equipment designs and provide complete process solutions. Combined with our full analysis of material characteristics and measurements of material behavior in specific processing applications, you are assured an efficient, reliable and safe solution, all backed by our process warranty. Field testing with rental equipment is available when lab testing would not effectively simulate process operating environments.

Aftermarket Parts & Services

Carrier offers a full line of aftermarket parts for its equipment. Our Aftermarket Sales Team will assess your parts needs and recommend the best solution. Our engineers are available to assist in any redesign or retrofit your existing equipment for new applications.

AMERICAS

Carrier Vibrating Equipment, Inc.
3400 Fern Valley Rd
Louisville, KY 40213, United States
Tel: +1-502-969-3171 | Fax: +1-502-969-3172
carriervibrating.com | cve@carriervibrating.com

EUROPE

Carrier Europe SA
Rue Joseph Luns 52
B-1401 Nivelles, Belgium
Tel: +32 67 40 01 40
carriereurope.be | ceur@carriereurope.be

CHINA

Carrier Vibrating Equipment (Shanghai) Co., Ltd.
#1 Bldg., #88 Shenzhou Road, Fengcheng Town
Fengxian District | Shanghai, 201411 China
Tel: +86 21-33925800
cves@carriervibrating.com.cn

