

Vibrating *Fluid Beds*

Since 1950, Carrier Vibrating Equipment has been known internationally as the pioneer in vibration technology, founded on a reputation for solving unique processing challenges. Carrier vibrating fluid beds are custom designed, engineered and manufactured for efficiency and reliability. We serve a broad range of industries, including chemicals, synthetics, pharmaceuticals, food and dairy, minerals, and biomass, to name a few.

Uniquely engineered for each application, Carrier vibrating fluid beds are highly efficient in drying and cooling a wide variety of products at a wide range of feed rates. Vibration aids in the fluidization and movement of difficult-to-process materials while preventing hot spots, burnt sides or areas left wet.



Process More Materials:

- Difficult-to-fluidize products
- Materials with wide particle size distribution
- Granular or crystalline solids
- Filter cakes or powders
- Fibrous materials
- Temperature-sensitive materials
- Fragile or brittle products



Features & Benefits

- Low fluidizing velocity design for maximum energy efficiency
- Plug flow delivers consistent first-in, first-out material output
- High temperature designs provide minimal footprint and maximum efficiency
- Zoning allows multiple functions to be performed in a single piece of equipment to optimize material processing efficiency
- Re-circulated gas and closed-loop systems available for greater efficiency or solvent recovery
- Available in low or high vibration designs to accommodate all types of material characteristics

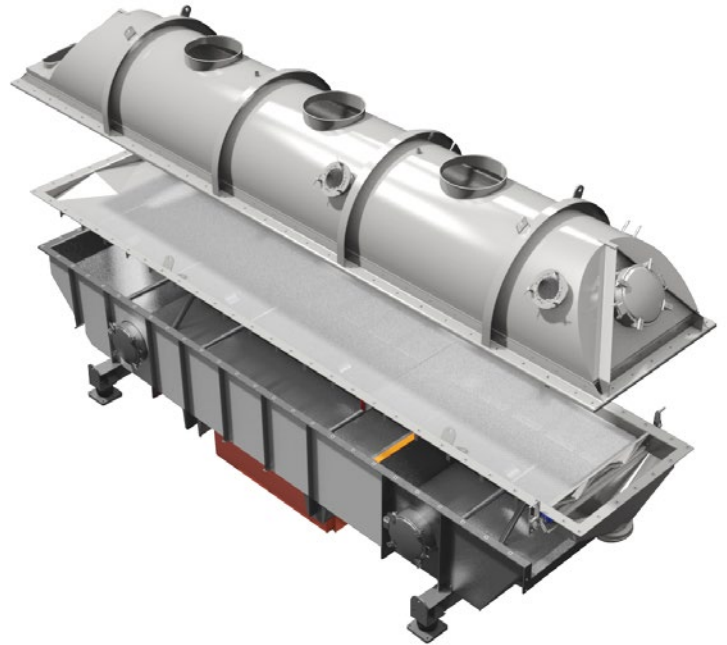

Options

Patented Delta-Phase® Drive

Make on-line changes to the angle of vibration for precise control of retention time, maximum fluidization, and processing of multiple products.



Access Manways & Doors

Access the plenum and deck with a variety of manways and doors.

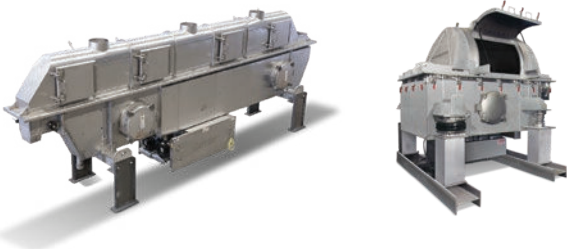

Custom Controls

Minimize field commissioning work with simple starter panels or customized PLC-based controllers complete with remote startup and engineering services.

Safety Features

All dryer system components can be designed with fire and explosion prevention, detection and suppression systems.

Fluidized Decks

Ensure precise airflow and consistently distributed heat with the proper fluidizing deck for your application - over 100 Carrier deck designs.

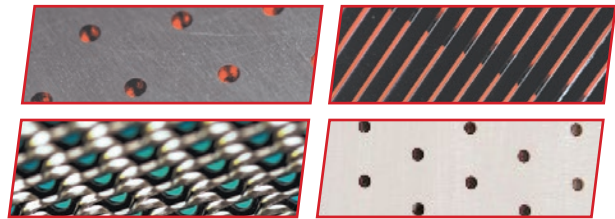

Iso-Max™ Dynamic Reaction Reducer

Significantly reduce the low dynamic reaction transmitted through the fluid bed isolation springs by up to 96%.



Materials of Construction

Material contact surfaces can be fabricated from carbon steel, stainless steel, titanium, Inconel® or a number of other alloys. Specialized coatings are available to reduce product adhesion.

Solvent Recovery

Remove or recover evaporated solvents during drying.

Integrated Systems

Standalone or complete multistep processing solutions.

Industries & Applications

From the most delicate materials to bulky ores, Carrier vibrating fluid beds apply harmonic motion to handle your materials without degradation.

- Plastic Pellets
- Food & Dairy
- Pharmaceuticals
- Minerals & Ores
- Chemical Compounds
- Catalysts
- Pelletized Minerals
- Coal
- Fertilizer
- Pet Foods
- Salt
- Rubber/Crumb Rubber
- Foundry Sand Reclamation
- Biomass & Wood
- Refuse, Recycled Glass
- Bauxite/Clay
- Frac Sand, Sand & Gravel
- And much more

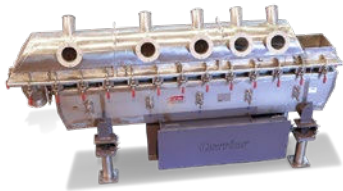

Chemical Compounds

- Efficient, easily cleaned
- Optimized processing of temperature-sensitive materials



Minerals/Ores & Frac Sand

- Heavy-duty
- High-temperature processing
- Process a wide range of particle sizes



Food & Dairy

- USDA/3A certified
- Clean-In-Place
- Sanitary processing



Polymers & Plastics

- Low maintenance
- Gentle, time-sensitive processing of sticky or demanding materials

Complete Systems For Process Optimization & Energy Efficiency

Carrier Fluid Bed Processors are specifically designed to provide a continuous passage of air through the product bed for efficient drying and cooling and minimum retention time. From once-through fluid bed process systems and partially recirculated systems to self-inerting fully recirculated systems, Carrier designs complete customized solutions optimized for your process.

With over 70 years of experience in the engineering, design and manufacture of drying and cooling technology, Carrier's complete systems are:

- Cost-effective, optimized & energy-efficient
- Customized in construction & application
- Reliable, easy to operate & low maintenance

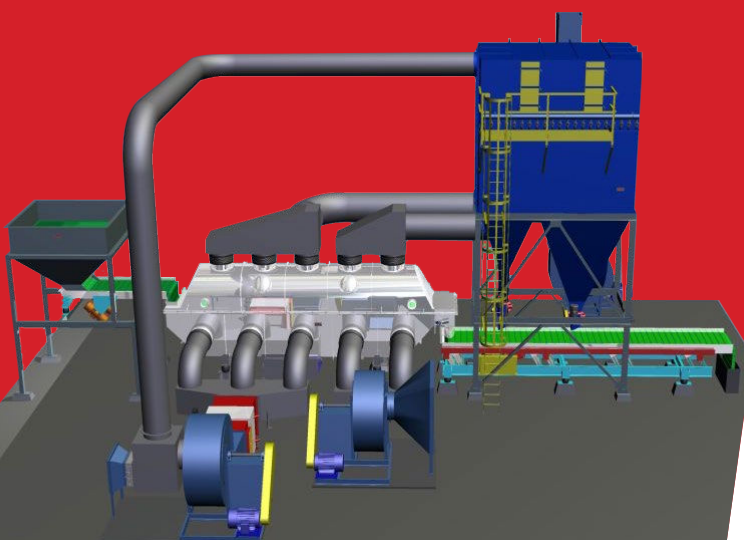

Engineering & Manufacturing

- Technology profile of over 150 patents
- Equipment designs are verified using Finite Element Analysis (FEA) to ensure trouble-free service and long life
- 3D equipment modeling
- State-of-the-art manufacturing facilities on 3 continents with robotic cutting and welding
- Manufacturing expertise working with mild steel, various grades of stainless steel, duplex stainless and other exotic alloys for specialty applications
- Welders certified to ASME & AWS standards
- ISO 9001:2015 certified

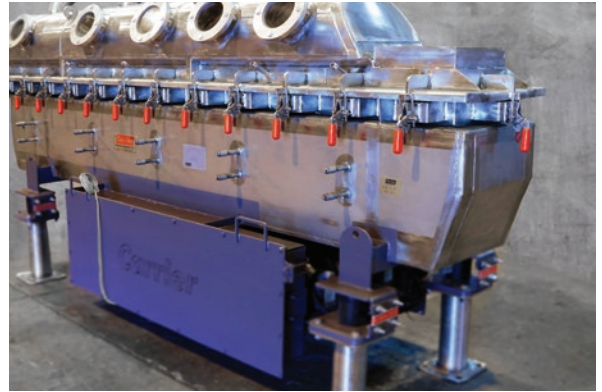

Lab Testing

Be confident that your powder and bulk solids processing is efficient with CPEG's 15,000 ft² state-of-the-art test lab. With our lab, you have access to the most extensive testing capabilities in the industry. Multiple pieces of equipment can be combined for multistep and multistage testing to simulate field operation, validate new equipment designs and provide complete process solutions. Combined with our full analysis of material characteristics and measurements of material behavior in specific processing applications, you are assured an efficient, reliable and safe solution, all backed by our process warranty.

Field testing with rental equipment is available when lab testing would not effectively simulate process operating environments.



AMERICAS

Carrier Vibrating Equipment, Inc.
3400 Fern Valley Rd
Louisville, KY 40213, United States
Tel: +1-502-969-3171 | Fax: +1-502-969-3172
carriervibrating.com | cve@carriervibrating.com

EUROPE

Carrier Europe SA
Rue Joseph Luns 52
B-1401 Nivelles, Belgium
Tel: +32 67 40 01 40
carriereurope.be | ceur@carriereurope.be

CHINA

Carrier Vibrating Equipment (Shanghai) Co., Ltd.
#1 Bldg., #88 Shenzhou Road, Fengcheng Town
Fengxian District | Shanghai, 201411 China
Tel: +86 21-33925800
cves@carriervibrating.com.cn



**EMPLOYEE
OWNED**